

Aluminium tube platform legs,
60 x 60 x 3 mm with a non-adjustable closing flap



Aluminium tube platform legs,
60 x 60 x 3 mm with adjustable polyamide load balancers



Telescopic platform legs with grid,
adjustable with safety stirrups,
additional height adjustment,
c. 40 mm, through polyamide load balancers

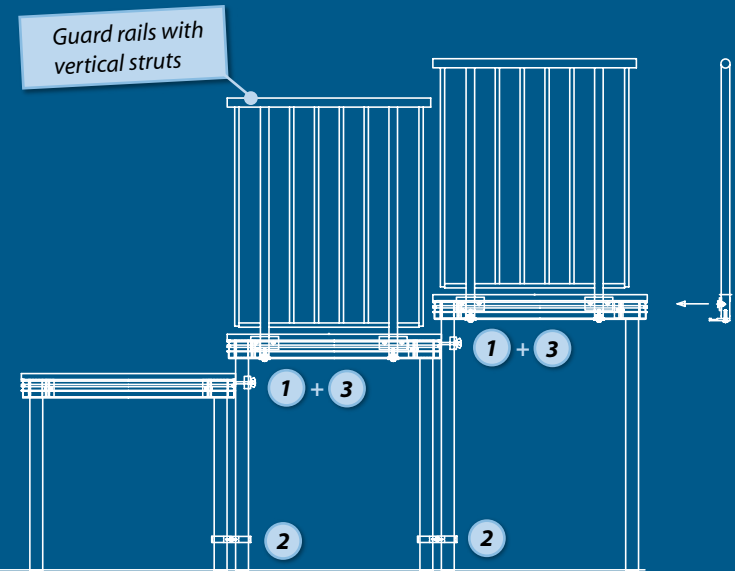
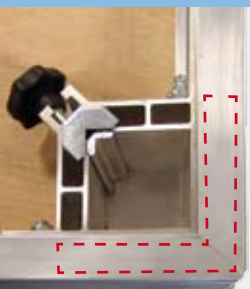

1



External mounting leg connectors
to connect the stage structure with the platform legs of the Dino with stepped arrangement (stage structure undercut)

you use **external platform leg connectors**



2



Railing connections
with additional connection of the platform leg for stepped and horizontal arrangement of the Dino stage

3



Internal mounting foot connections
to connect 2 mounting feet with the stage structure for the stepped arrangement of the Praktikus stage (stage structure undercut)

you use **internal platform leg connectors**



■ This will even take the load of a bear!

Our Dino stage is always used when a stage is required to withstand exceptional loads. It doesn't matter if it's outside or inside. For example, this mobile stage section offers various design possibilities but also varied combination options for any sporting, music or dance event. Dino can be designed either as a one-level stage or as a stage on several levels and can be erected up to a height of 3m (with additional bracing).

Edge protection for flooring or subfloor is guaranteed. The surrounding groove ensures accuracy of fit for all our accessories.

At just 12 cm stacking height, the Dino stage is a truly compact element with the standard platform dimension measuring 100 x 200 cm.



The other advantages of this stage assure a smooth, problem-free set-up before the start of the event:

Sturdy Due to its sealed aluminium rectangular frames within internally pressure-grouted corner angles

Stable (safe against overturning) on account of the corner angles being bolted to the frame

Compatible by using an adapter that fits all the stage sections

Creative by using straight or arched profile designs

Compact on account of the stage sections being connected with short and long quick-fit connectors

Complies with regulations Stages and standard or positioning rails correspond to the guidelines specified by the Ordinance on Places of Assembly.

■ The all-purpose platform - perfect for any application

Dino lives up to its name: the easy-to-assemble stage ranks among the most robust platform of its kind, and is therefore specifically designed for professional use.

Of particular note is the considerable load-bearing capacity, with the safety standards authority tested statics of 750 kg/m² in accordance with DIN 4112. The Dino stage can also be erected up to 2 m high without bracing and up to 3 m high with bracing.

Stage height:
up to 2 m high without bracing
up to 3 m high with bracing

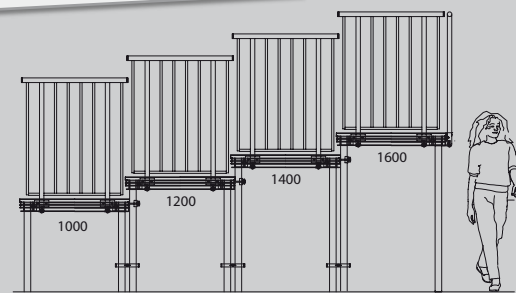

Straight and arched profile design – anything is possible

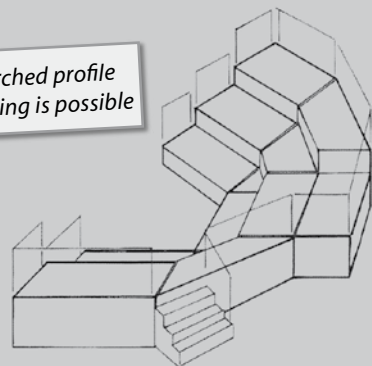

■ Extensive range of accessories to complement your stage

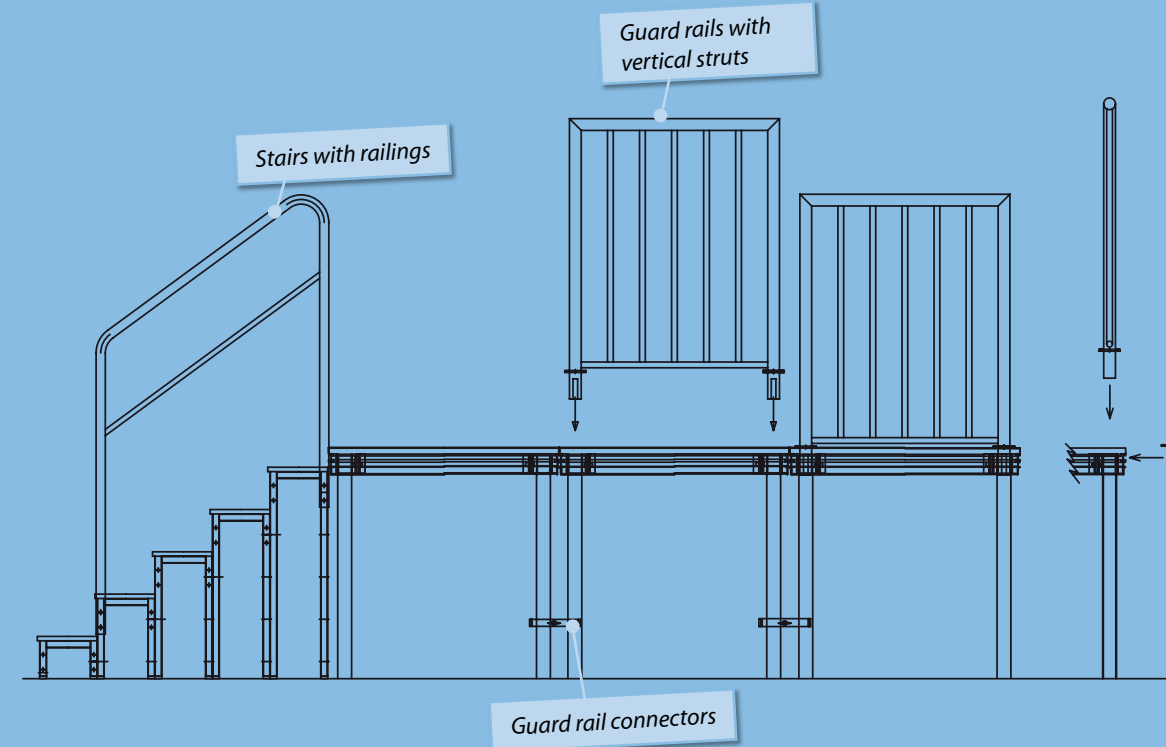

Surrounding **assembly rails** for fixing the stage accessories and edge protection for the stage flooring

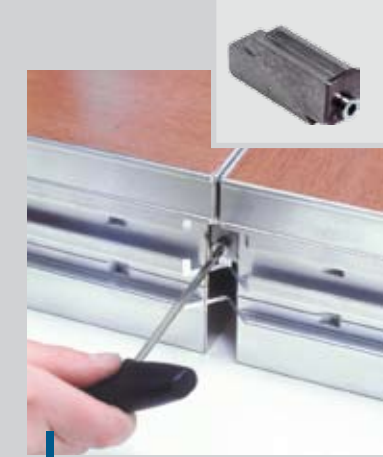

Short quick-fit connectors to fasten the stage sections to each other in the edge region (accessories)



Long quick-fit connectors, to fasten the stage sections to each other in the interior area (accessories)



Corner angles with large surface-flush nuts (80 mm in length) lend the individual stage sections firm support even at maximum heights



Corner angles with retaining springs

Internal, pressure-grouted **corner angles**

